

sidecar spare parts

october 2010



IDEAL – Motorräder & Seitenwagen GmbH
Köpenicker Straße 8 · D – 10997 Berlin / Germany · tel: +49 (0)30 / 618-6258 · fax: +49 (0)30 / 611-7002
mail: info@ideal-seitenwagen.de · url: www.ideal-seitenwagen.de

Business hours: Monday to Friday 10:00 a.m.-17:00 p.m. · Saturday 10:00 a.m.-13:00 p.m.

Terms of Delivery

Spare parts are shipped within 3 days after receipt of order. Packing costs are determined by package size and usually run between 1,54 € and 9,13 €. Shipping and handling costs including insurance are assumed by the customer. If you require more than the standard insurance we will arrange that for you.

Please note that we have to bend alu trimmings for shipping!

All prices are quoted with tax included (19% VAT). For Customers outside of European Union (EU) we will be happy to prepare an export certificate or deliver for the Netto price. We reserve the rights to price changes. Estimates are subject to change and not binding. Legal jurisdiction for all matters is Berlin, Germany.

Payment Terms

All orders are sent after receipt of payment or bank transfer. If you wish we accept C.O.D. (cash on delivery).

All merchandise remains property of this company until payment in full is received.

Warranty Terms

All spare parts are carefully produced and inspected before packing. If there is a problem, we will exchange or refund your money. The guarantee does not extend to parts damaged due to faulty installation by the customer.

All parts carry a 6 month normal wear guarantee. All returned or exchanged merchandise which does not fall under the guarantee terms are subject to a service fee of 10% of the purchase price or 15 € minimum and any other costs incurred in the return or exchange of said merchandise is the responsibility of the customer.

Impressum:

IDEAL – Motorräder & Seitenwagen GmbH · Köpenicker Straße 8 · D – 10997 Berlin / Germany

tel: + 49 (0) 30 / 618-6258 · fax: + 49 (0) 030 / 611-7002 · mail: info@ideal-seitenwagen.de · url: www.ideal-seitenwagen.de

Registered office: Handelsregister Amtsgericht Berlin-Charlottenburg · HRB 93452 B

Business manager Dipl.-Ing. Stefan Klinkenberg · Sales manager Stefan Klein

St.Nr.: 1129 403 04201 57 0506 · VAT-IdNo.: DE 23587 45 63

Bank account: Berliner Volksbank · BLZ: 100 900 00 · Konto: 722 192 00 01 · IBAN: DE10100900007221920001 · BIC: BEVODEBB

Editorial staff: Stefan Klinkenberg, Stefan Klein

Motorräder *ideal* Seilenwagen

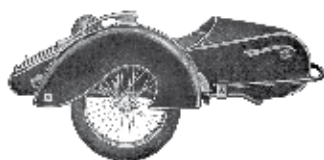

LS 200

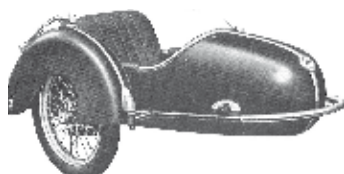

S 250



S 350

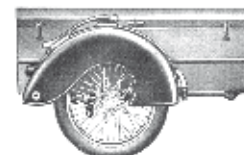

LT 200



S 500

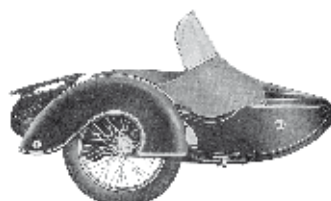

TR 500



RS 1



T 1

We manufacture original facsimiles from STEIB LS 200, S 350, S 500 and TR 500 just like those produced in Nürnberg in the mid-50's. STEIB sidecars were offered as standard equipment for Motorcycle firms from that era. All components are exact copies and compatible with the original STEIB models.

Our order numbers are based on the system of the original STEIB catalogue. This will help you to find the required parts for the restoration of your sidecar.
Reprints of the original STEIB catalogues are available – ask for them!

We deliver connecting parts, frames, reinforced springs and spoke wheels for a wide variety of motorcycles. We supply a extensive selection of spares for BMW R 24 – R 27, R 50 – R 69 S and R 51/2 – R 68. For pre-war BMW, HOREX Regina, EMW and AWO we offer the most often requested parts.

Feel free to ask about parts you don't find in our catalogue. We will make an offer suitable to you.

Actual information can be found on our homepage www.ideal-seitenwagen.de!

LS 200 / LT 200 – sidecar boat – suspension	S. 4/5
S 250 – spare parts	S. 6/7
S 350 / S 500 – sidecar boat – suspension	S. 8/9
TR 500 – sidecar boat – suspension	S. 10/11
RS 1 and T 1 – sidecar boat – suspension	S. 12/13
fender – lamps	S. 14/15
wheel – brake – axle – tire	S. 16/17
frames – identification plates – bumper	S. 18/19
bike connectors	S. 20/21
adapter frame for BMW Boxer 1969 – 96	S. 22/23
interior upholstery	S. 24
dust covers – windscreens	S. 25
manuals and spare part lists	S. 26
motorbike parts	27
our sidecars	28

LS 200 / RS 1 and LT 200 / T 1 – sidecar boat – suspension

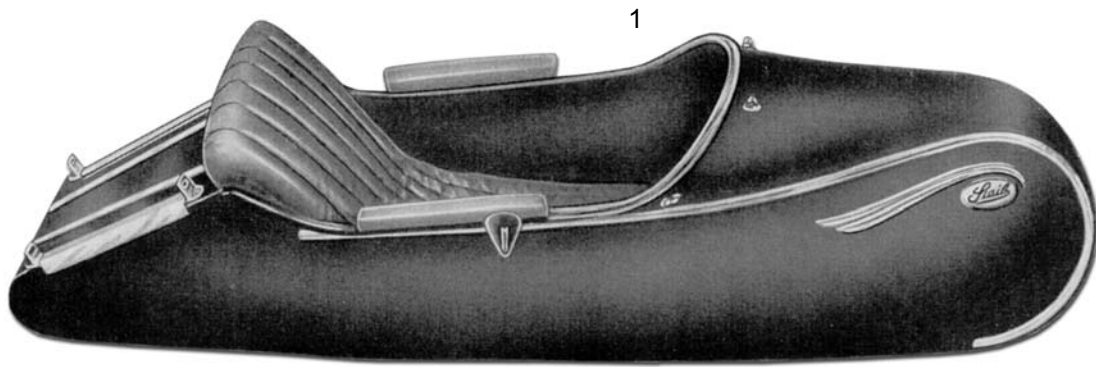

Interior upholstery is **not** included in the sidecar boat price.
Please check our offer in this catalogue!

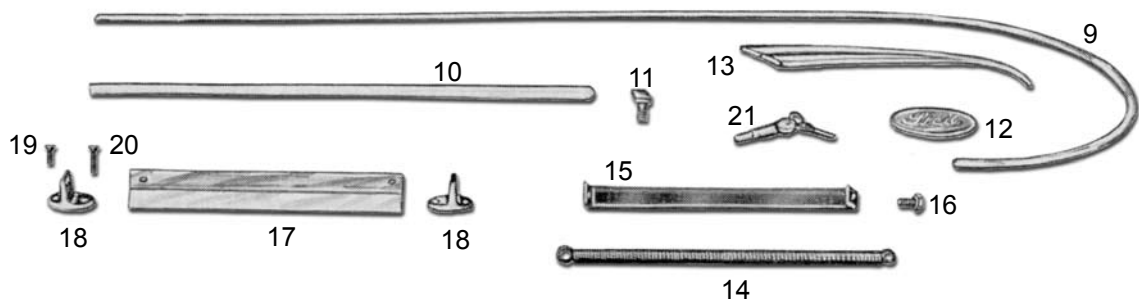
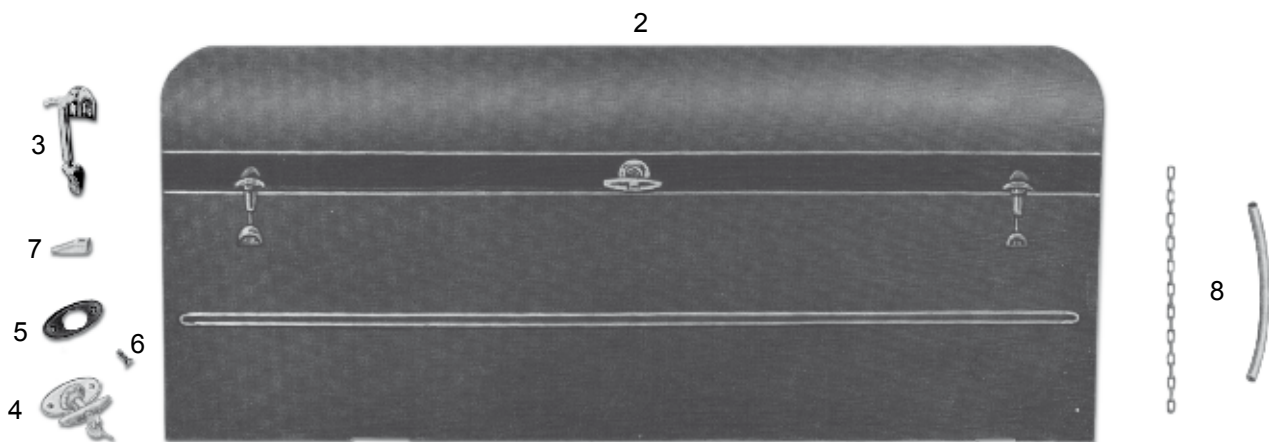

rubber ring suspension, complete

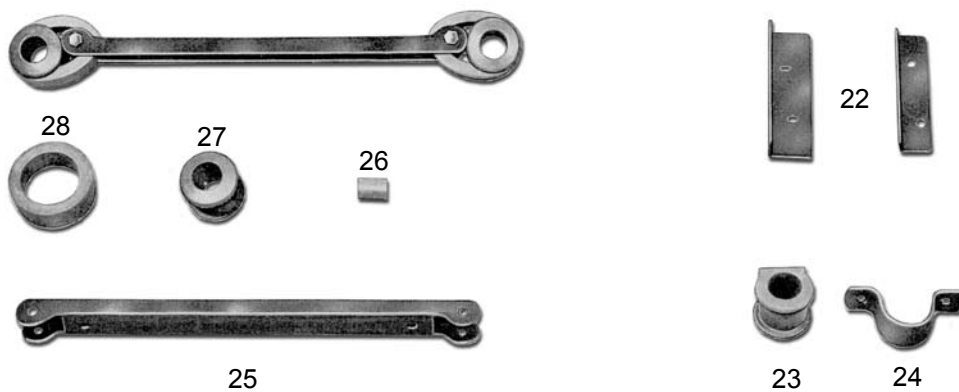

LS 200 / RS 1 and LT 200 / T 1 – sidecar boat – suspension

pict.	order-no	article	price
1	S600z5Z	boat LS 200 / RS 1 , primed, with alu trim, footrest, luggage bar & -hooks, without seat & interior upholstery	1.290,00 €
2	S600z10	boat LT 200 / T1 , complete, primed, with locks L = 140 cm, W = 41 cm, H = 56 cm	1.290,00 €
3	S400z291	lock , stainless steel and polished alu, with screws	49,00 €
4	S400z98k	handle lock , for luggage door, includes nose piece, rubber gasket, screws	56,90 €
5	S123z5	rubber gasket , for handle lock	3,00 €
6	S151z98VA	screw , M 5 x 16, stainless, for handle lock	0,30 €
7	S102z2	nose piece , for handle lock	9,90 €
8	S141z7	chain for luggage door , 3 mm x 315 mm, with protective poly tubing	5,00 €
9	S200z226P	trimming for LS 200, bended, pair, polished aluminium	42,90 €
	S200z227	trimming for LS 200, polished aluminium, pair for luggage rack, rear	21,90 €
10	S500z6	trimming for all STEIB models , 2 m, polished aluminium	19,00 €
11	S131z104	trimming fastener , 12 mm	0,77 €
12	S200z124	badge STEIB , oval LS 200	22,00 €
13	S200z125	badge eyebrow trim LS 200	19,90 €
14	S141z61	seat spring , S 350 / S 500, 360 mm, (seat requires 9 springs)	6,90 €
	S141z6Hv	front bracket for seat spring , to be welded	21,00 €
15	S121z93	footrest LS 200	14,90 €
16	S151z40VA	screw M 6 x 12, stainless, LS 200 – S 500, coach bolt for footrest, polished head	3,00 €
17	S132z15	luggage bar , LS 200, polished aluminium	24,90 €
18	S102z27	luggage hook , LS 200, S 350, polished aluminium	15,00 €
19	S151z27VA	screw , M 4 x 12, stainless, LS 200 / S 350, for luggage hook	0,30 €
20	S151z28VA	screw , M 4 x 16, stainless, LS 200 / S 350, for luggage hook, inside	0,30 €
21	S200z53	lock for seat , LS 200 & original S 350	16,50 €
	S200z53a	tube for seatlock LS 200 and original S 350	6,50 €
	S200z53b	steel sheet for seatlock LS 200 and original S 350, stainless, mounted at seat	7,00 €
	S200z53c	rosette for seatlock LS 200 und Original S 350 for welding on the boat	6,50 €
22	S121z32R	bracket , undrilled, LS 200 & LT 200, stainless, polished	8,00 €
23	S103z11	rubber bearing , LS 200 & LT 200 front	15,90 €
24	S121z29	clamp , LS 200 & LT 200 front	9,50 €
25	S121z179	U-profile boat suspension , LS 200 & LT 200, without rubber S103z46 & S103z44	25,90 €
26	S103z44	alu bearing LT 200 / LS 200, 8 x 22 x 30 mm, (requires 2 pieces)	7,90 €
27	S103z45	rubber suspension mount , frame rear	10,90 €
28	S103z46v	suspension rubber ring , stronger rubber	20,90 €
	Notification:	for LT 200 you need a double boat suspension	

S 250 – spare parts

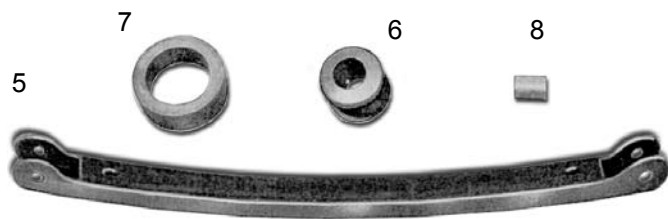
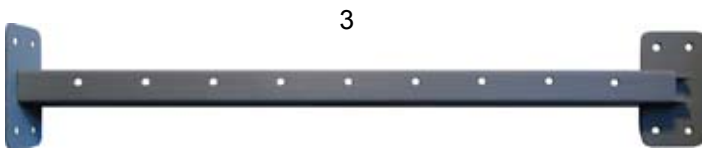
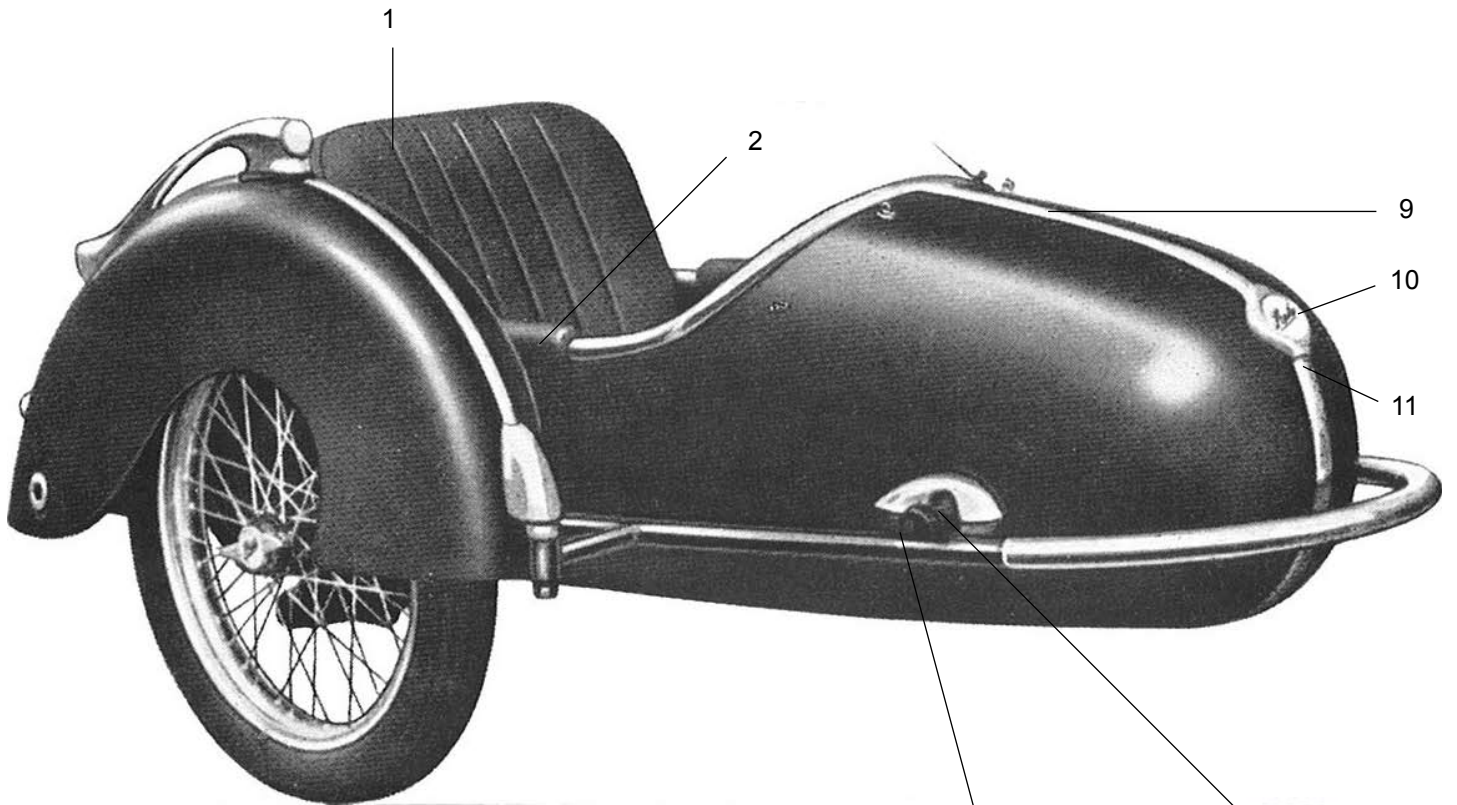

S 250 – spare parts

pict.	order-no	article	price
1	S600z07or	seat S 250 original , red, 2-parts	189,00 €
	S600z07os	seat S 250 original , black, 2-parts	189,00 €
	S123z7Pr	upholstery pannels for S 250 , red with map pocket	89,00 €
	S123z7Ps	upholstery pannels for S 250 , black with map pocket	89,00 €
	S103z361	floor carpet set for S 250 , two pieces, for boat & luggage room	39,50 €
2	S400z82r	arm rest, pair S 250 red	26,00 €
	S400z82s	arm rest, pair S 250 black	26,00 €
	S400z82h	arm rest holder S 250 VA (4 pieces necessary)	10,00 €
	S600z161S	dust cover	89,00 €
3	S141z6HvS250	front holder for seat spring, S 250 , L = 495 mm, with fastening on the side, to be welded or screwed	49,90 €
	S141z611	seat spring , 420 mm	6,90 €
4 4a	S113z3 S113z4	rubber bearing S 250 , front cone mount, front, cover for rubber bearing	99,00 € i. V.
5	S121z181	U-profile boat suspension, S 250	29,90 €
6	S103z45	rubber suspension mount , frame rear	10,90 €
7	S103z46v	suspension rubber ring , stronger rubber	20,90 €
8	S103z44	alu bearing LT 200 / LS 200, 8 x 22 x 30 mm, (requires 2 pieces)	7,90 €
9	S200z230	trimming set S 250 , bended, polished, with 4 screws, 3 pieces	109,00 €
10	S102z8	badge STEIB for S 250	24,90 €
11	S102z8k	badge STEIB for S 250 , complete with holder	49,90 €
	S102z81	badge STEIB for S 250 , holder only	29,90 €
12	S200z231	end cap for trimming at the seat , alu polished	14,90 €
13	S600z754T3	identification plate for S 250	8,50 €
	S102z17	alu foot rest complete	6,90 €
	S600z7Ö	fixing parts set for dust cover for S 250	19,90 €

S 350 / S 500 – sidecar boat – suspension

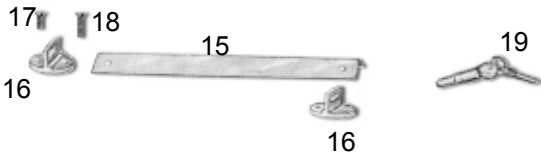
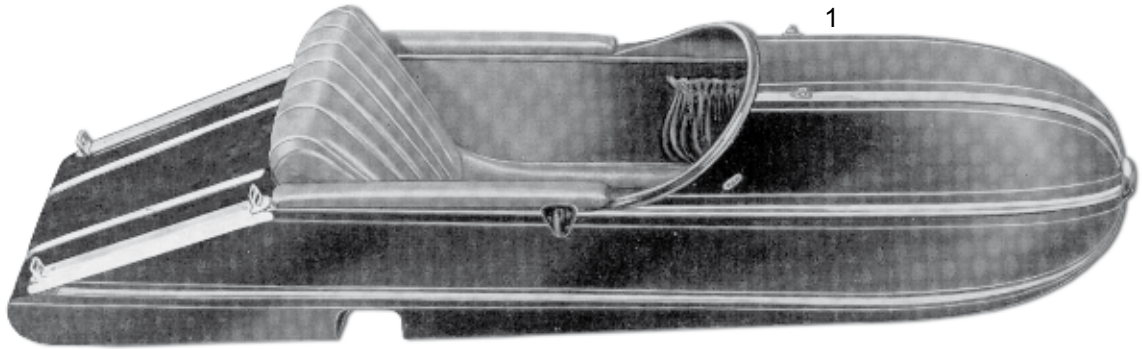

Interior upholstery is **not** included in the sidecar boat price.
Please **check our offer** in this catalogue!

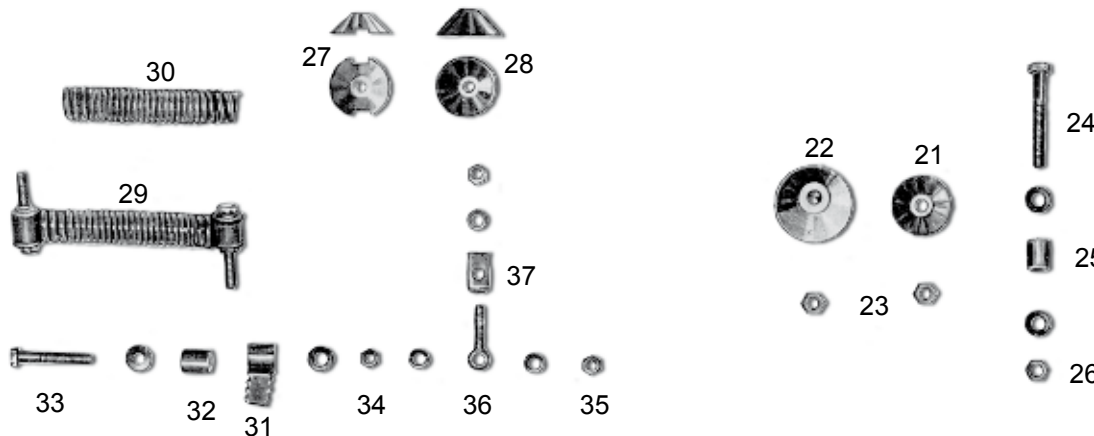
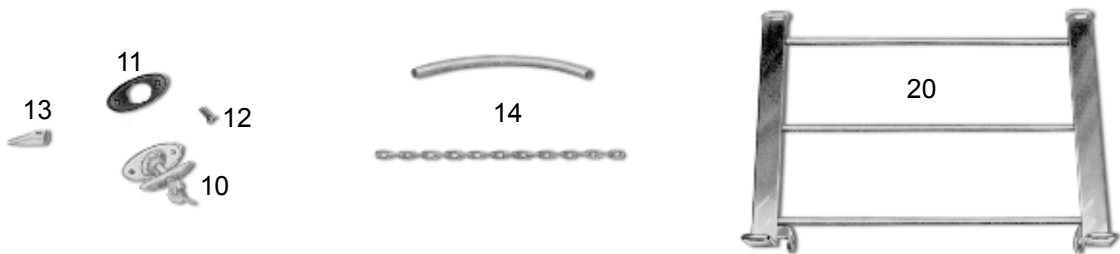
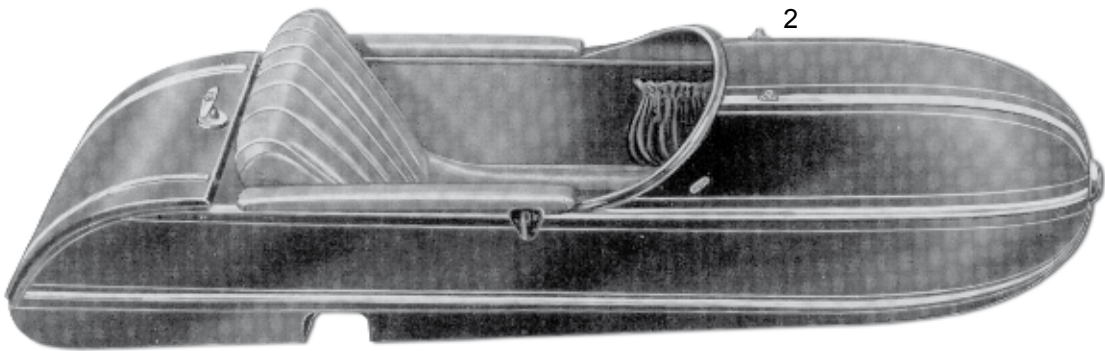

S 350 / S 500 – sidecar boat – suspension

pict.	order-no.	article	price
1	S600z12Z	boat S 350 , primed, with alu trim, front badge, footrest, luggage bar & -hooks, without seat & interior upholstery	1.450,00 €
2	S600z17Z	boat S 500 , primed, with alu trim, front badge, footrest, without seat & interior upholstery	1.590,00 €
	S600z17EF	welded holder front segment S 500	49,90 €
	S600z17EK	welded holder luggage ground S 500	39,50 €
3	S102z9	badge STEIB , for S 350, S 500	19,90 €
	S102z9H	badge HOREX , for S 350, S 500	19,90 €
4	S123z2	rubber gasket , for badge	7,90 €
	S141z6Hh	rear holder for seat spring , S 350 / S 500, to be welded	21,00 €
	S141z6Hv	front holder for seat spring , S 350 / S 500, to be welded	21,00 €
5	S141z6	seat spring , S 350 / S 500, (seat requires 9 springs), 440 mm also available: 330 mm, 360 mm, 420 mm	6,90 €
6	S500z6	trimming , 2 m, polished aluminium	19,00 €
	S200z228	pair of trimming , S 350 luggage rack 65 cm	21,90 €
	S500z7	trimming set S 350 , complete, without fastening	105,00 €
	S500z8	trimming set S 500 , complete, without fastening	105,00 €
7	S131z104	trimming fastening , 12 mm	0,79 €
8	S121z40	footrest , primed	15,90 €
9	S151z40VA	screw M 6 x 12 V2A, coach bolt for footrest, polished head	3,00 €
10	S400z98k	handle lock , for luggage door, includes nose piece, rubber gasket, screws	59,90 €
11	S123z5	rubber gasket , for handle lock	3,90 €
12	S151z98VA	screw M 5 x 16, stainless, for handle lock	0,30 €
13	S102z2	nose , for handle lock	9,90 €
	S400z97	luggage door , S 500, primed, without lock	125,00 €
	S103z48	rubber sealing , for luggage door S 500, 1000 mm	7,00 €
14	S141z7	chain for luggage door , ~350 mm, with protective poly tubing	5,50 €
15	S132z16	luggage bar , S 350, polished aluminium	25,90 €
16	S102z27	luggage hook , LS 200, S 350, polished aluminium	15,00 €
17	S151z27VA	screw M 4 x 10, stainless, for luggage hook	0,30 €
18	S151z28VA	screw M 4 x 16, stainless, for luggage hook, inside	0,30 €
19	S200z53	lock for seat , LS 200 & original S 350	16,50 €
20	S600z20	luggage bar , S 500, complete with fastening, polished aluminium	259,00 €
21	S102z3	cone mount S 350 / S 500 front, 65 mm, 14 mm hole	23,90 €
22	S102z5	cone mount , original S 350, front, 78 mm, 13 mm hole	24,90 €
23	S131z103VA	nut M 14, stainless, S 350 / S 500 front cone mount	2,10 €
24	S151z103VAp	screw M 14 x 100, stainless, polished, orig. S 350, front cone mount	9,50 €
24	S151z104VAp	screw M 14 x 90, stainless, polished, S 350 / S 500, front cone mount/frame	9,00 €
25	S113z2	rubber, front cone mount , 14 x 25 x 30 mm, S 350 / S 500,	6,50 €
26	S131z105VA	nut M 14, stainless, S 350 / S 500, front cone mount	2,10 €
27	S102z4	rear boat fixing cone , S 350 / S 500 rear, 65 mm, 12 mm hole, with long gap	23,90 €
28	S102z56	rear boat fixing cone , original S 500, 65 mm, 12 mm hole, without gap	23,90 €
29	S400z233VA	suspension , S 350 / S 500, stainless, stiffer spring, with inserts & rubber	99,50 €
30	S141z4VA	spring , stainless, S 350 / S 500, stiffer, without inserts & rubber	56,90 €
31	S121z22	inserts for spring , LS 200 – S 500, without rubber	19,90 €
32	S113z1	rubber for inserts , 12 x 25 x 30 mm, also for LS 200 old version	6,50 €
33	S151z81VAp	screw M 12 x 80, stainless, polished, S 350 / S 500, inserts/frame	6,50 €
	S151z81kVAp	screw M 12 x 70, stainless, polished, S 350 / S 500, inserts/frame	6,50 €
34	S131z64VA	nut M12, flat, stainless, S 350 / S 500, inserts/frame	1,20 €
35	S131z65VA	nut M12, stainless, S 350 / S 500, rear boat fixing	1,50 €
36	S101z121VA	eye screw , stainless	12,90 €
37	S121z138	washer for eye screw , stainless, polished	7,90 €

IDEAL – Motorräder & Seitenwagen GmbH · Köpenicker Straße 8 · D – 10997 Berlin · tel: +49 (0)30 / 618-6258 · fax: +49 (0)30 / 611-7002



TR 500 – sidecar boat – suspension



Interior upholstery is **not** included in the sidecar boat price.
Please check our offer in this catalogue!

spare wheel holder

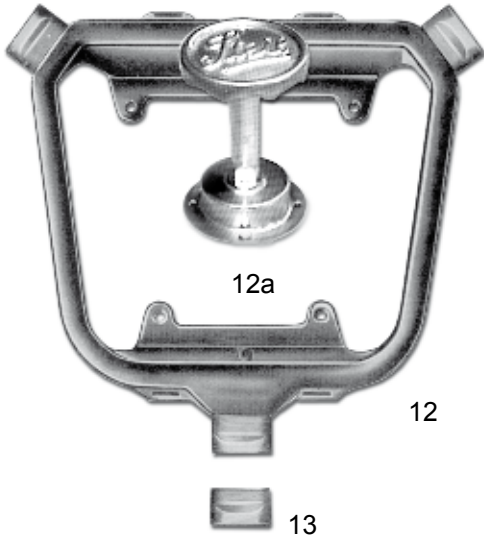

leaf spring suspension

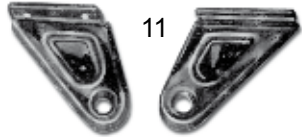

rubber ring suspension

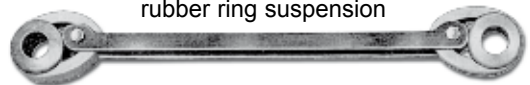

16

TR 500 – sidecar boat – suspension

pict.	order-no.	article	price
1	S600z62G	boat TR 500, steel, rubber suspension , primed, without interior, footrest, handle grip, latches	1.550,00 €
	S600z62F	boat TR 500, steel, leaf spring suspension , primed, without interior, footrest, handle grip, latches	1.599,00 €
2	S102z24	handle grip , TR 500	42,00 €
3	S151z24VAp	screw M 8 x 25, round-head bolt for handle grip, stainless, polished	5,50 €
4	S103z42	rubber gasket for badge	2,90 €
5	S102z31	badge STEIB , round, for TR 500	15,90 €
6	S200z76	latch , without lock, chromed	89,00 €
7	S200z75	latch , with lock, chromed	99,00 €
8	S151z27VA	screw M 4 x 12, stainless	0,30 €
9	S112z5	mounting set for luggage door complete: bolt, bush, nut, 2 washers, (requires 2 pieces)	18,90 €
	S103z47	rubber gasket for luggage door	7,50 €
10	S141z22	chain for luggage door , 680 mm, with protective poly tubing	7,95 €
	S400z245	luggage door , primed, with bolts, without latches	153,00 €
11	S121z112k	foot rest , complete	45,00 €
12	S200z95	spare wheel holder , primed, without wing nut & mounting bolt	219,00 €
12a	S400z272k	spare wheel mounting bolt , complete, with wing nut or STEIB front badge	129,00 €
13	S103z5	rubber for spare wheel holder , (requires 3 pieces)	10,90 €
14	S103z32	rubber bearing , between frame & boat, front	15,90 €
15	S121z102	clamp for boat , front TR 500	24,50 €
16	S121z180	U-profile boat suspension , without rubber S103z46 & S103z44	25,90 €
17	S103z45	rubber suspension ring bushing , rear	10,90 €
18	S103z46v	rubber suspension band , stronger	20,90 €
19	S103z44	alu bearing , spacer/bushing for U-profile, 8 x 22 x 30 mm	7,90 €
20	S400z238	leaf springs , pair	220,00 €
21	S103z41	rubber bumper , between frame & boat, rear TR 500, for leaf spring suspension model only	7,50 €
22	S101z124	spring holder	75,00 €
23	S200z93	upper silentblock , requires screw M 16 x 1,5 x 55 (S151z124VA)	22,00 €
24	S200z94	lower silentblock , requires screw M 12 x 1,5 x 65 (S151z125VA)	22,00 €
25	S151z124VAp	screw M 16 x 1,5 x 55, stainless, polished	11,90 €
26	S121z118	cap spring holder , chromed	10,90 €
27	S151z136	U-bolt for leaf spring	11,50 €
28	S151z125VA	screw M 12 x 70, stainless	3,90 €

RS 1 and T 1 – sidecar boat – suspension

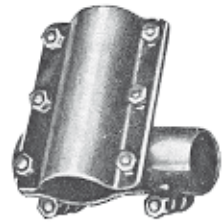
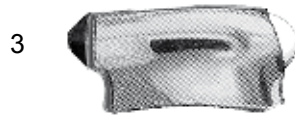
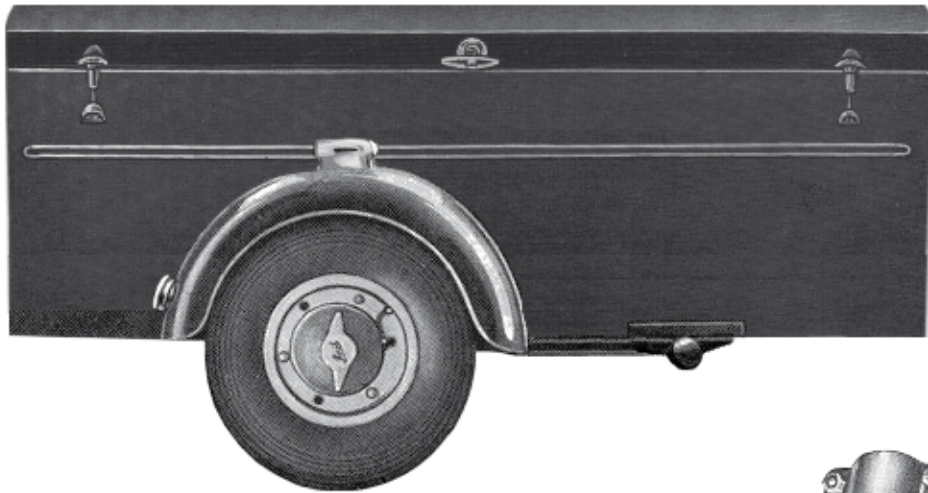
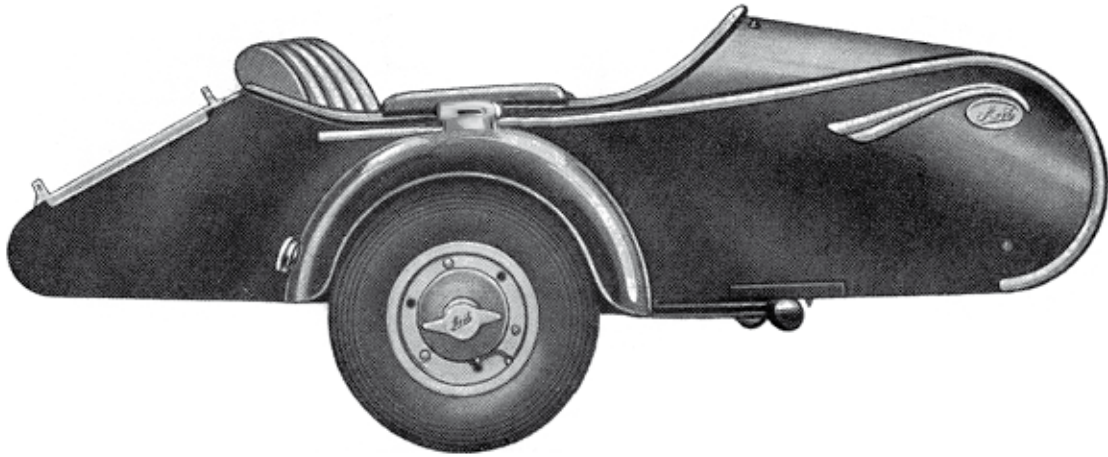

11

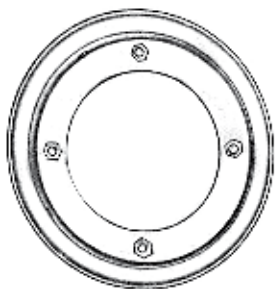
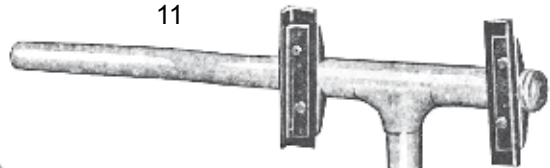

9

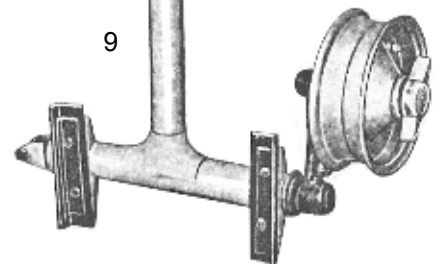

RS 1 and T 1 – sidecar boat – suspension

pict.	order-no.	article	price
1	S701z90	STEIB sidecar RS 1 – primed with interior upholstery complete, wheel complete, connectors for Heinkel-Rolller, trimming, luggage bar, position lamp	2.990,00 €
1a	S600z5Z	boat RS 1 / LS 200 , primed, with trimming, footrest, luggage hook and bar, without: badge eyebrow trim, badge STEIB, seat and interior upholstery	1.290,00 €
2	S701z91	STEIB sidecar T 1 , primed, with wheel complete, position lamp, connecting parts for Heinkel	2.890,00 €
2a	S600z10	boat T 1 / LT 200 , complete, primed, with locks L = 140 cm, W = 41 cm, H = 56 cm	1.290,00 €
3	S400z298	position lamp RS 1 , complete with lenses red/white and rubber gasket	189,00 €
4	S200z102E	reflex reflector DIN 72616	5,50 €
5	S121z280	fender RS 1 , primed, without extra parts, suitable for 8"-10"	169,00 €
6	S121z250	steel rim 10" , coated, reground, 4-hole	95,00 €
7	S121z297	hub complete 10" , 4-hole, new manufacture, suitable for axles: 20 mm	159,50 €
8	S102z37	wing nut , M 18 x 1.5, for STEIB axle 22 mm	27,50 €
9	S600z90	frame RS 1 , primed with swinging arm, axle: 20 mm, suitable for 8"-10", without connecting parts, wheel and angle S121z32R	895,00 €
10	S200z168	cross clamp Heinkel Tourist	119,50 €
11	S200z169	connecting pipe Heinkel Tourist	59,00 €
	S121z251	tire Conti Zibby , 4.00 x 10"	35,00 €
	S121z252	tube , 4.00 x 10"	8,90 €
	S600z83R	identification plate for RS 1	8,50 €
<p>All other spares on page 5, LS 200, interior upholstery, dust covers and windscreens on pages 24/25</p>			

IDEAL – Motorräder & Seitenwagen GmbH · Köpenicker Straße 8 · 10997 Berlin · Tel.: 030 / 618-6258 · Fax: 030 / 611-7002



fender – lamps

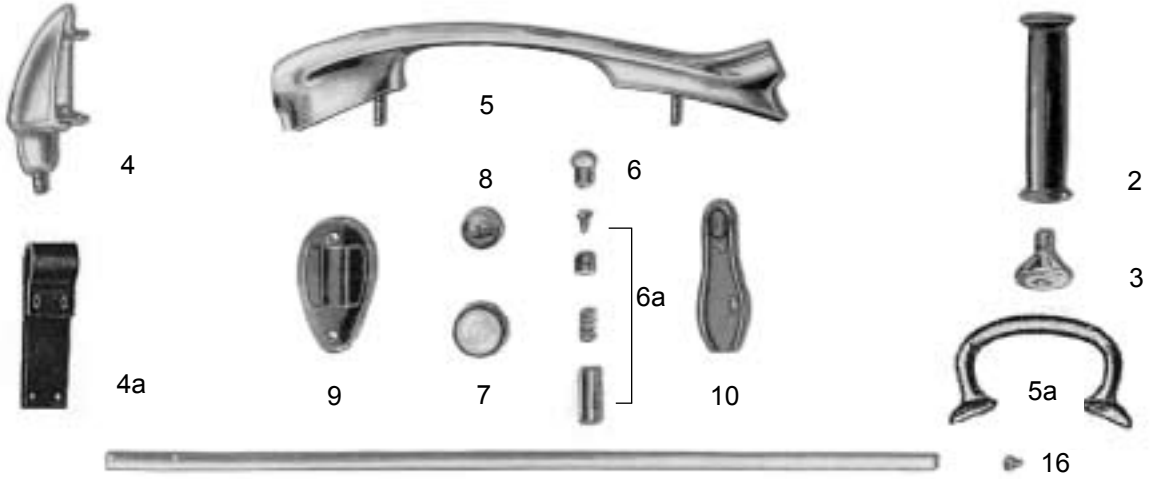

fender – lamps

pict.	order-no.	article	price
1	S200z122 S200z122a	fender LS 200/ S 500, steel, 16 cm, primed, without extra parts fender LS 200 / S 500, steel, old version till 1952, without sickle, primed, without extra parts	249,00 € 249,00 €
1	S200z122L S200z153 S200z153a	fender LS 200 – 500, steel, left hand, primed, without extra parts fender TR 500, 18 cm, primed, without extra parts fender TR 500, steel, old version till 1952, without sickle, primed, without extra parts	249,00 € 259,00 € 259,00 €
1a	S400z87	fender open , steel, primed for prewar models no. 28 / no. 31, and up to 1951	239,00 €
2	S200z123	distance pipe , LS 200 – S 500, for fender	10,90 €
2	S200z123T	distance pipe , TR 500, for fender	11,90 €
3	S102z15	conical screw , for fender holder rear	24,50 €
4	S102z14	fender holder , front	45,00 €
	S121z55	rubber gasket , for fender holder front	10,50 €
4a	S151z72	fender holder , for prewar modells, stainless, polished, drilled for our fenders, undrilled for universal use	49,00 €
5	S102z22K	Cobra lamp , polished alu, STEIB-form, complete, with lamp socket, lenses and rubber gaskets	198,00 €
5a	S400z83	handle grip , for our fenders, prewar models no. 28 / no. 31, alu polished	62,60 €
6	S122z8k	lamp socket , complete with spring, for Cobra lamp	9,50 €
6a	07119978220	bulb for Cobra lamp , 6V, 5W	1,75 €
	07119978222	bulb for Cobra lamp , 12V, 5W	1,75 €
	07119978221	bulb for Cobra lamp , 6V, 10W	2,60 €
	07119978224	bulb for Cobra lamp , 12V, 10W	2,60 €
7	S103z24	lens for Cobra lamp , front, white	8,90 €
8	S103z25	lens for Cobra lamp , back, red with STEIB print	8,90 €
	S103z24o	lens for Cobra lamp , front, amber, for turn signal	11,90 €
	S103z25o	lens for Cobra lamp , back, amber with STEIB print, for turn signal	11,90 €
9	S103z27	rubber gasket for Cobra lamp, front	9,90 €
10	S103z49	rubber gasket for Cobra lamp, back	9,90 €
11	S400z246	reflex reflector with polished alu housing	37,90 €
	S200z102E	reflex reflector DIN 72616	5,50 €
12	S400z171	position lamp TR 500 , white, "Eberleuchte" with reflector & rubber gasket	76,95 €
13	S400z172	position lamp TR 500 , red, "Eberleuchte" with reflector & rubber gasket	76,95 €
	07119978330	bulb 6V, 5W, for "Eberleuchte" position light	2,60 €
	07119978331	bulb 12V, 5W, for "Eberleuchte" position light	2,60 €
	07119978303	bulb 6V, 10W, for "Eberleuchte" brake light	2,60 €
	07119978304	bulb 12V, 10W, for "Eberleuchte" brake light	2,60 €
14	S400z171G	rubber gasket for "Eberleuchte"	8,00 €
	S400z171F	lens for "Eberleuchte" position light, white, with reflector	9,00 €
	S400z172F	lens for "Eberleuchte" position light, red, with reflector	9,00 €
	S400z172A	ring for lens "Eberleuchte" position light, aluminium	9,00 €
	S300z3	plug for light cable, 12 mm	5,00 €
15	S500z6	trimming , 2 m, polished aluminium	19,00 €
	S200z229	trimming set fender , applicable for Cobra lamp and reflex reflector	23,90 €
	S500z6k	trimming fender , 135 cm	15,00 €
16	S131z104	trimming fastener , 12 mm	0,79 €
	New!		
17	S200z121	bumper for fender LS200 – S500, stainless, with front holder	125,00 €
18	S102z10	position lamp Universal , e.g. for prewar sidecars	179,00 €

wheel – brake – axle – tire

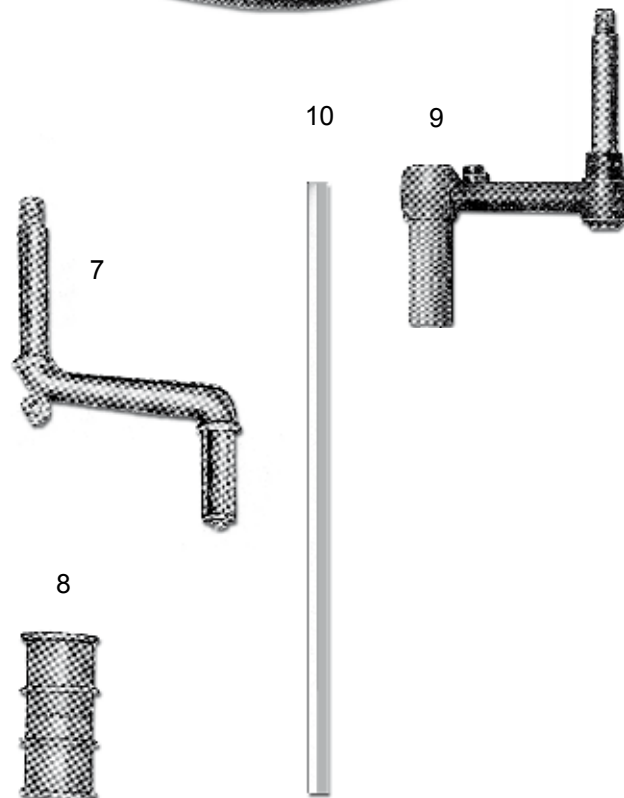
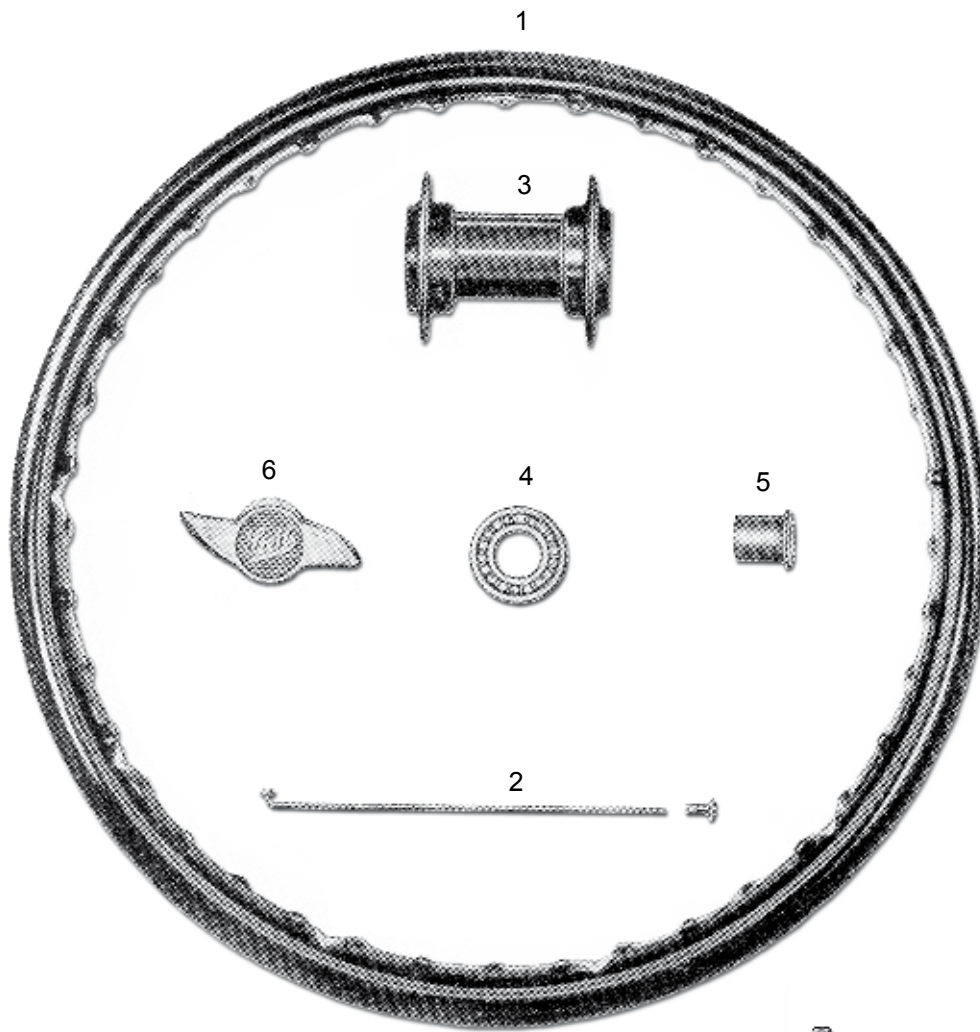

wheel – brake – axle – tire

pict.	order-no.	article	price
	S400z236d19	wheel, steel rim 19" , rim & spokes chromed, without tire	299,00 €
	S400z236d18	wheel, steel rim 18" , rim & spokes chromed, without tire	299,00 €
	S400z236d19n	wheel, steel rim 19" , rim chromed, stainless spokes, without tire	319,00 €
	S400z236d18n	wheel, steel rim 18" , rim chromed, stainless spokes, without tire	319,00 €
1	S131z119d	steel rim 19" , chromed,	109,00 €
	S131z118d	steel rim 18" , chromed,	109,00 €
2	S131z019c	spoke 19" , chromed, with nipple, 213 mm x M 3,5	1,10 €
	S131z018c	spoke 18" , chromed, with nipple, 200 mm x M 3,5	1,10 €
	S131z019n	spoke 19" , stainless, with nipple, 213 mm x M 4	1,55 €
	S131z018n	spoke 18" , stainless, with nipple, 199 mm x M 4	1,55 €
3	S400z223	hub, STEIB-wheel , without brake, black, with bearings & bushes	135,00 €
4	S101z108L	bearing 6205 2RS , for STEIB wheel & swinging arm	10,00 €
5	S121z134	bushing , for wheel LS 200 – S 500, 25/22 mm x 30 mm	9,50 €
	S121z134T	bushing , for wheel TR 500, 25/20 mm x 30 mm	9,50 €
6	S102z37	wing nut , M 18 x 1.5, LS 200 – S 500, for STEIB axle 22 mm	27,50 €
	S102z38	wing nut , M 20 x 1.5, TR 500, for BMW axle 20 mm	27,50 €
		wheel suspension complete for welding on the frame	ask for price
7	S101z104	swinging arm , LS 200 – S 500, with ID-number	155,00 €
8	S200z97	rubber block , LS 200 – S 500, without screw	27,90 €
	S600z83F	rubber suspension arm , LS 200, precision casting, for welding	89,00 €
	S600z54F	rubber suspension arm , S 350 / S 500, precision casting, for welding	119,00 €
	S101z105	bearing housing , LS 200 – S 500, precision casting, for welding	139,00 €
9	S200z206	swinging arm , TR 500, torsion bar, without housing	289,00 €
	S200z206B	bushing for swinging arm, TR 500	89,00 €
	S200z206S	protective caps for swinging arm, TR 500	15,00 €
	S200z206H	stay tube for torsion bar, for welding	79,00 €
	S200z206To	torsion bar , steel, TR 500, without swinging arm & housing, original version	45,00 €
10	S200z206k	swinging arm , TR 500, complete, with torsion bar & housing, for welding	550,00 €
	00000325-18	tire 3.25-18 "Cheng Shin"	39,00 €
	00000350-18	tire 3.50-18 "Cheng Shin"	39,00 €
	00000325-19	tire 3.25-19 "Cheng Shin"	39,00 €
	00000350-19	tire 3.50-19 "Cheng Shin"	39,00 €
	0000M350-19C	tire 3.50-19 , Metzeler Block C	75,00 €
	0000M400-18K	tire 4.00-18 , Metzeler Block K, sidecar	89,00 €
	0000S300-18	tube 3.00-3.50-18	12,00 €
	0000S300-19	tube 3.00-3.50-19	12,00 €
	0000S400-18	tube 3.25-4.00-18	12,00 €
	0000S400-19	tube 3.25-4.00-19	12,00 €
	0000000F-18	rim rubber 18/19"	3,00 €

frames – Identification plates – bumper

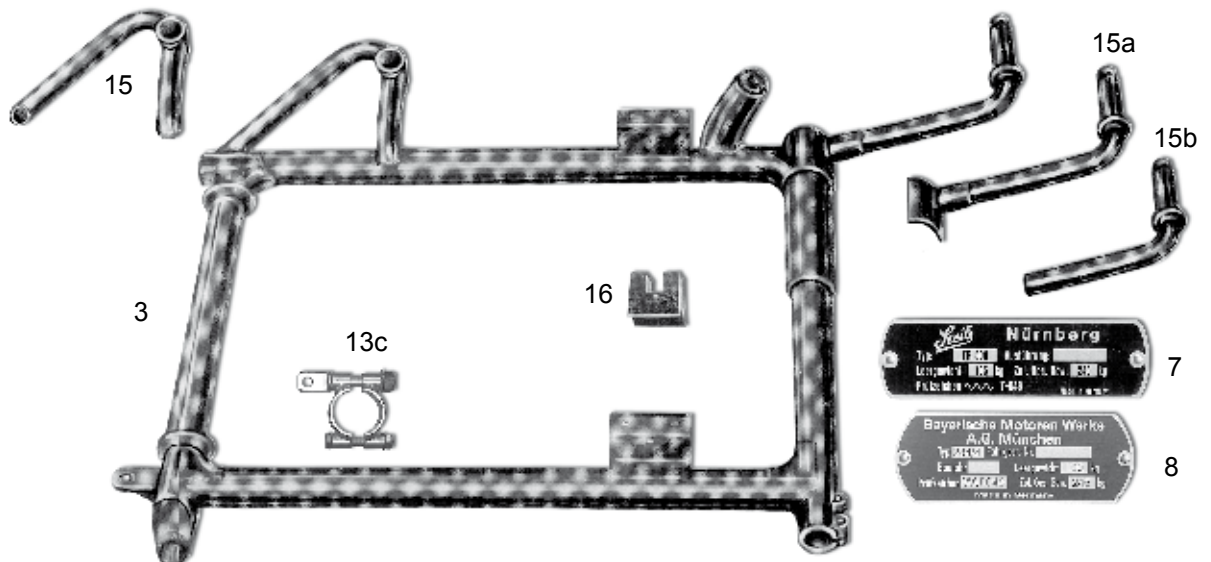
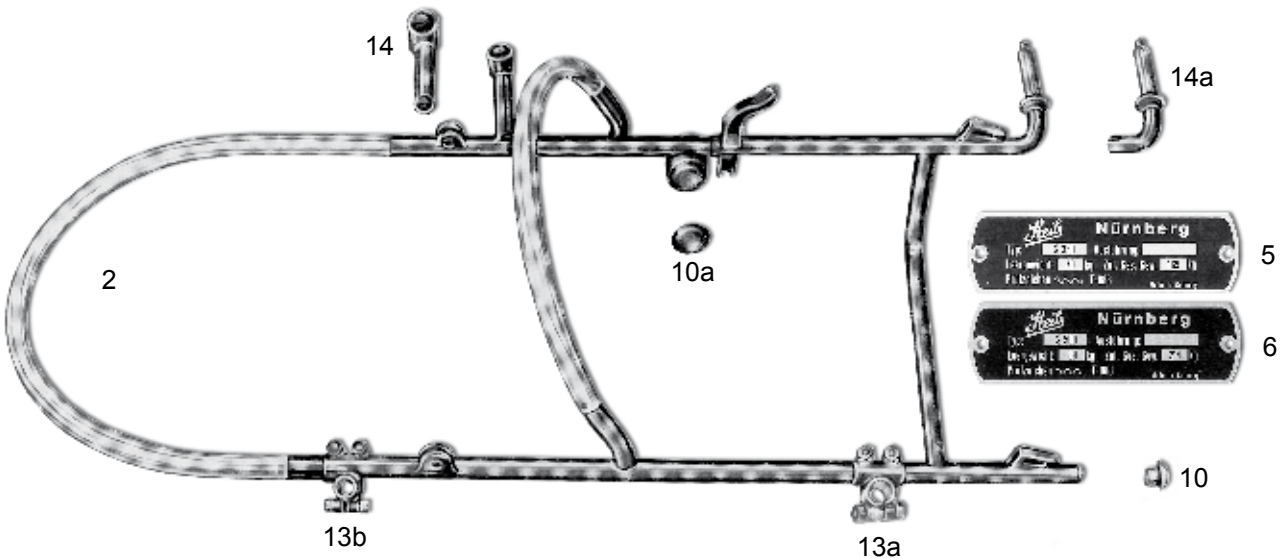
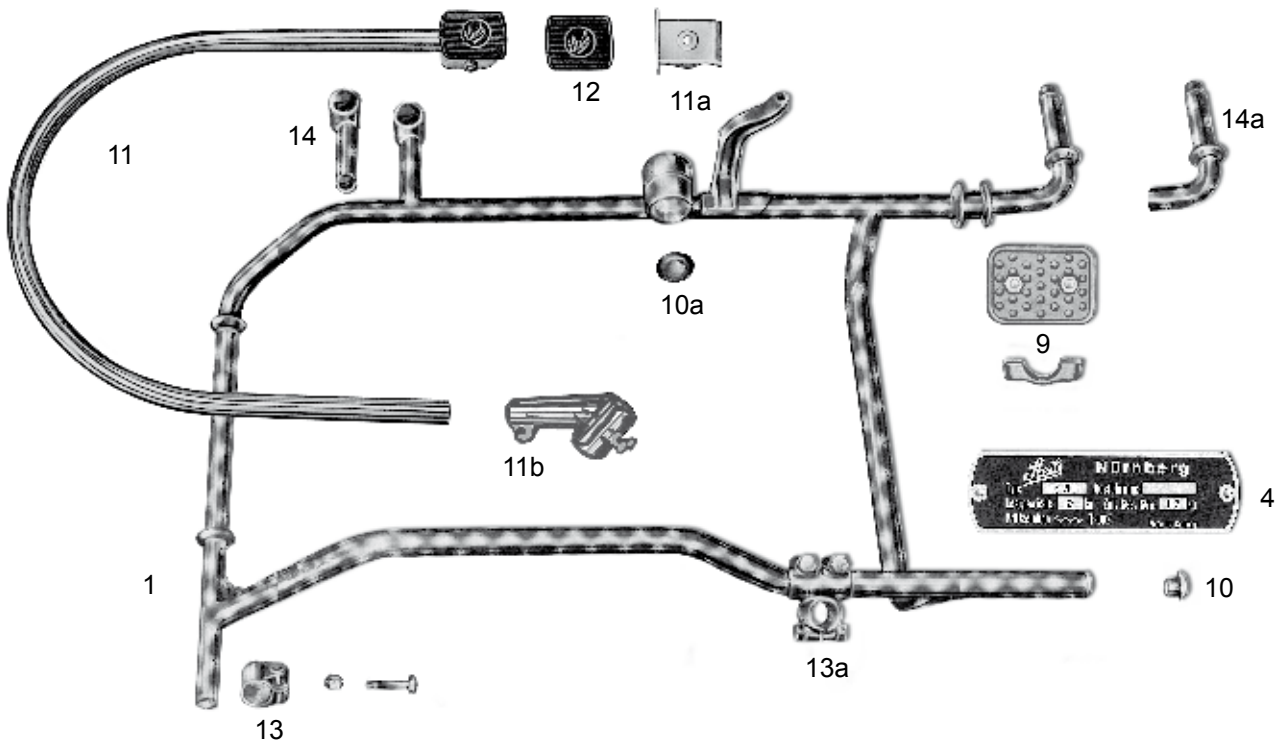

frames – identification plates – bumper

pict.	order-no.	article	price
1	S600z83	frame, LS 200 , primed, with clamps & swinging arm, without extra parts	850,00 €
2	S600z54	frame, S 350/ S 500 , primed, with clamps & swinging arm, without extra parts	1.090,00 €
3	S600z86F	frame, TR 500 , spring suspension model, primed, with swinging arm & torsion spring, without extra parts	1.695,00 €
	S600z86G	frame, TR 500 , rubber suspension model, primed, with swinging arm & torsion spring, without extra parts	1.650,00 €
4	S600z83T	identification plate for LS 200	8,50 €
5	S600z54T2	identification plate for S 350	8,50 €
6	S600z54T1	identification plate for S 500	8,50 €
7	S600z86T1	identification plate for TR 500	8,50 €
8	S600z86T2	identification plate for BMW-Spezial, TR 500	8,50 €
9	S102z17	alu foot rest complete , LS 200 – TR 500, with clamp S102z18	32,00 €
10	S102z29	cap , frame tube end, LS 200 / S 350 / S 500, 32 x 6 mm, polished aluminium	6,90 €
10a	S121z8	bearing cover , swinging arm LS 200 / S 350 / S 500, polished aluminium	8,90 €
11	S112z1	bumper , steel, LS 200	79,50 €
11a	S102z13P	clamp for bumper , LS 200, right side, polished aluminium	49,90 €
11b	S102z19	clamp for bumper , LS 200, left side, coated with zink	42,00 €
12	S103z15	pace rubber with STEIB imprint	18,50 €
13	S101z135	clamp , boat fixing front LS 200, inner diameter = 32 mm	25,90 €
13a	S200z84	cross clamp , rear, 32 x 32 mm, fine castings, x-ray checked	95,00 €
13b	S200z208	cross clamp , front, 27 x 32 mm, fine castings, x-ray checked	95,00 €
	S200z84g	cross clamp , parted, rear LS 200, 32 x 32 mm	99,00 €
	S200z208g	cross clamp , parted, front S 350 / S 500, 27 x 32 mm	99,00 €
13c	S101z128	clamp with flat bolts, for sidestay, TR 500	45,00 €
	S151z84VA	screw M 12 x 60, stainless, for S 350 / S 500 cross clamp	2,00 €
14	S200z59	fender holder , front LS 200 – S 500, to be welded	48,00 €
14a	S200z99	fender holder , rear LS 200 – S 500, to be welded	27,00 €
15	S200z58	fender holder , front TR 500, to be welded	55,00 €
15a	S200z77	fender holder , rear TR 500, to be screwed to frame, leaf spring suspension	55,00 €
15b	S200z78	fender holder , rear TR 500, to be welded, rubber suspension	32,00 €
	S103z105	rubber bumper , for swinging arm LS 200	7,00 €
	S103z206	rubber bumper , for backside of swinging arm TR 500	7,00 €
16	S103z41	rubber bumper , for frame for spring model TR 500	7,90 €
	S103z4	rubber bumper , rear LS 200, old version with spring suspension	7,90 €

bike connectors



5



4

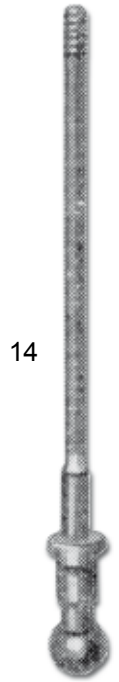

14

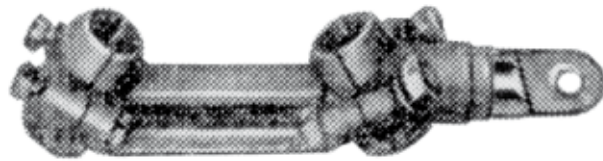

17

12



7

10



9



8



11

6



13



15

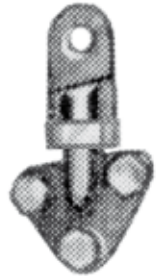

16

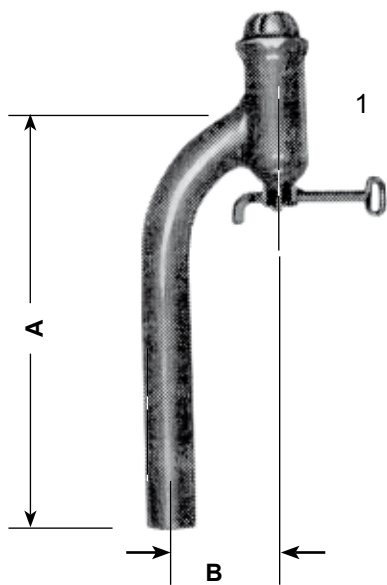

1



2

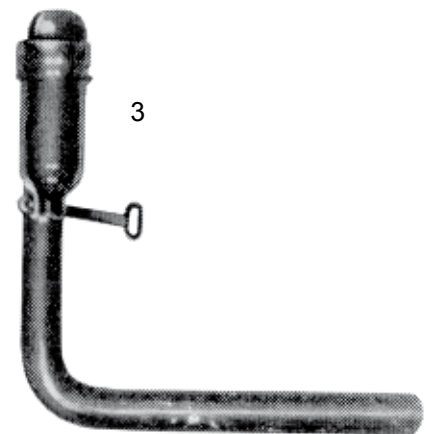

3

bike connectors

pict.	order-no.	article	price
1	S400z234	join coupling arm 27 mm, B = 120 mm, A = 270 mm	75,00 €
1	S400z234b	join coupling arm 27 mm, B = 70 mm, A = 270 mm	75,00 €
	S400z55	join coupling arm 32 mm, B = 70 mm, A = 270 mm	75,00 €
	S400z55a	join coupling arm 32 mm, B = 100 mm, A = 270 mm	75,00 €
	S400z7	join coupling arm 24 mm, massive, B = 70 mm, A = 270 mm	75,00 €
2	S400z239	join coupling arm 36 mm, B = 100 mm, for TR 500	75,00 €
2	S400z239e	join coupling arm 36 mm,small version, B = 50 mm, for TR 500, KS 601	75,00 €
3	S400z235	join coupling arm R 50, angle, 27 mm, B = 75 mm, A = 200 mm	75,00 €
	S400z235s	join coupling arm R 50, angle, 27 mm, B = 75 mm, A = 160 mm	75,00 €
		all join couplings without handle ...ask for more sizes!	
4	S111z54	side stays/ braces , threaded sleeve = 250 mm, winding rod = 150 mm, without clamps	55,00 €
4	S111z55	side stays/ braces , threaded sleeve = 350 mm, winding rod = 150 mm, without clamps	55,00 €
	S111z54k	side stays , complete, threaded sleeve = 250 mm, winding rod = 150 mm, with clamp, rubber & bolts	85,00 €
	S111z55k	side stays/ braces , complete, threaded sleeve = 350 mm, winding rod = 150 mm, with clamp, rubber & bolts	85,00 €
5	S200z89	side stays , threaded sleeve = 400 mm, winding rod = 150 mm, with two fork ends, for TR 500, without clamps	55,00 €
	S101z131	threaded sleeve for side stays ; M 18 x 1,5; 150, 200, 250, 300 350, 400 mm	from 33,00 €
	S101z130	eye screw for side stays M 18 x 1,5	15,90 €
6	S101z130	clamp , cast, nickel plated, for upper connector, LS 200 – S 500, (two pieces required)	19,50 €
	S103z43	rubber insert upper connector, (two pieces required)	5,50 €
7	S400z10	coupler , complete, without handle S101z6	45,00 €
8	S400z10S	split pin for coupler 4 mm x 50 mm	1,10 €
9	S101z6	handle for bell clamp	4,90 €
10	S101z62	jaw for bell clamp	16,90 €
11	S101z76	nut for bell clamp, foundry part	10,90 €
12	S300z2br/s	leather strap & buckle, <i>brown/black</i>	5,50 €
13	S101z127	motorcycle connector eye bolt M 14 x 20, for upper connector, front TR 500	19,90 €
13	S101z129	motorcycle connector eye bolt M 14 x 68, for upper connector, front TR 500	19,90 €
	S101z128	eye bolt , with fastener, for upper connector, TR 500	43,00 €
14	46519020183	ball pin connector , 12 mm, narrow end, for lower connector, for R 51/2 a.o.	30,00 €
14	46519020184	ball pin connector , 13 mm, thick end, for lower connector, for R 51/3 – 69/S	30,00 €
15	71609020180	3rd connector , 12 mm, M 12x50, for R 51/2 a.o.	15,50 €
15	71609020182	3rd connector , 13 mm, M 12x50, for R 51/3 – R 69/S	15,50 €
16	46519020221	3rd connector , flat, cast part for upper connector under saddle, for R 24 – 27	39,00 €
	46519020220	3rd connector , ball, cast part for upper connector under saddle, for R 24 – 27	39,00 €
17	46519020212	4th connector , with frame clamp, for R 24 – R 25/3 front	85,00 €
	46519020213	4th connector , with frame clamp, for R 26 – R 27 front	85,00 €
	S400z310	mounting ball , to be welded on the bike frame	20,00 €
	46519920126	additional frame with two lower ball connectors, for R 26	149,00 €
	46519020216	additional frame with two lower ball connectors, for R 27	149,00 €
	S151z54	screw M 10 x 60, stainless, for side stays/clamp, S 350 – S 500	1,10 €
	S151z55	screw M 10 x 40, stainless, for side stays/clamp, S 350 – S 500	1,10 €
	S131z55	nut , M 10, stainless, for side stays/clamp, S 350 – S 500	0,80 €
	S400z101	connector set for HOREX Regina , 2 eye bolts, 2 balls	99,00 €
	S400z102	connector set for MOTO GUZZI V7 , ball pin, clamp, eye bolt	199,00 €

adapter frame for BMW Boxer 1969 – 96

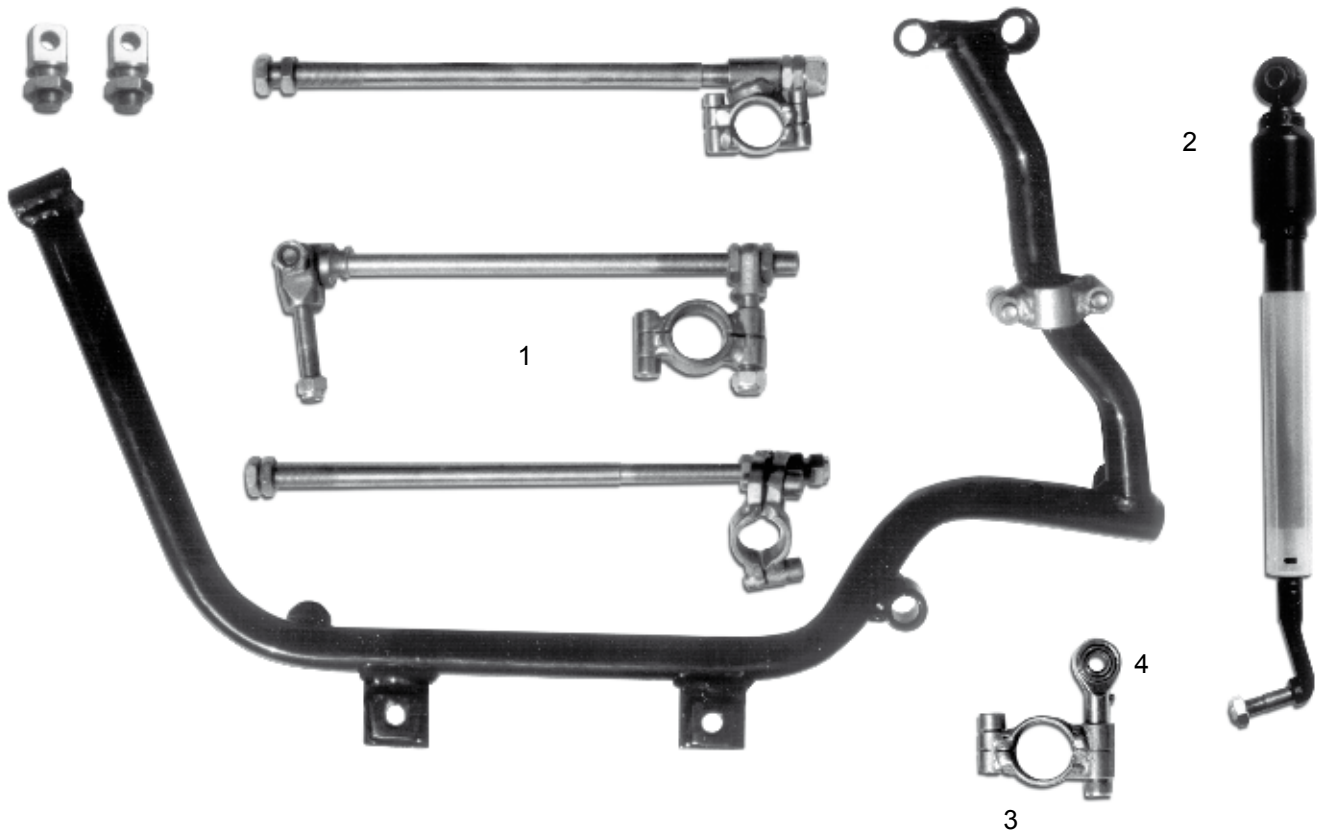

pict.	order-no.	article	price
1	46519020217	adapter frame , complete with clamps & stays	795,00 €
2	46519020218	steering damper	65,00 €
3	46519020219	clamp for steering damper	49,00 €
4	46519020210	socket-joint for steering damper	49,00 €

adapter frame for BMW Boxer 1969-96

information

General information

All of this models can be outfitted with sidecars. An adapter frame, screwed to the right side of the motorbike, makes it possible. In most cases a 4-point-connection is used. The adapter frame is made of welded steel pipes and is connected with adjustable clamps (to avoid applied tensions) to the motorbike frame. The adapter frame has two upper socket-joints and two lower flat bolts. The clamps and screws are zincked, the frame is black powder laminated and is outfitted with a registry number. The adapter frame, once mounted can remain on the motorbike when the sidecar is not in use.

Security information

- + Each adapter frame is TÜV (german state technical inspection) certified. This inspection certificate is available.
- + Generally casted rims are not accepted for use with sidecars by the german TÜV and therefore we do not recommend them.

Technical requirements

- + Installation time: approx. 1 – 2 hours.
- + This BMW models are not recommended for sidecar use:
BMW /5: frames are less stable (reinforcement of the steering heading is possible through alteration in a professional workshop).
BMW R45: no shorter transmission available.
- + The original tele-front forks are more susceptible to wear. It is recommended using a sleeve to give more tension to the front springs.
- + A front wheel swinging arm adds stability and is widely available. It generally costs about 1.500 €.
Hydraulic steering dampers are recommended for use on both suspension systems to avoid shimmying.
- + The back wheel suspension can be reinforced by stronger springs. For later GS-models a sleeve is adequate for extra support. Early G/S, with short swinging arm, should be equipped with a high quality spring (ex. Wilbers, White Power,...).

Adapter frames

There are three types of BMW Boxer. Each one requires a different adapter frame:

/5 to /7 distinguishable by its oval frame pipe underneath the steering heading.

Typ 247 all models up to the R100R/1996; GS with foldable footrests, distinguished by its round frame tubes, 32 mm diameter. The last GS has a shorter frame, the adapter requires a slight adjustment.

Typ 248 all R 45 and R 65

All 3 adapter frames are designed for use on BMW Boxer models with standard gas tank size. We offer special adapter frames for larger gas tank sizes.

Adapter frames for other motorcycles are also available on request!



interior upholstery

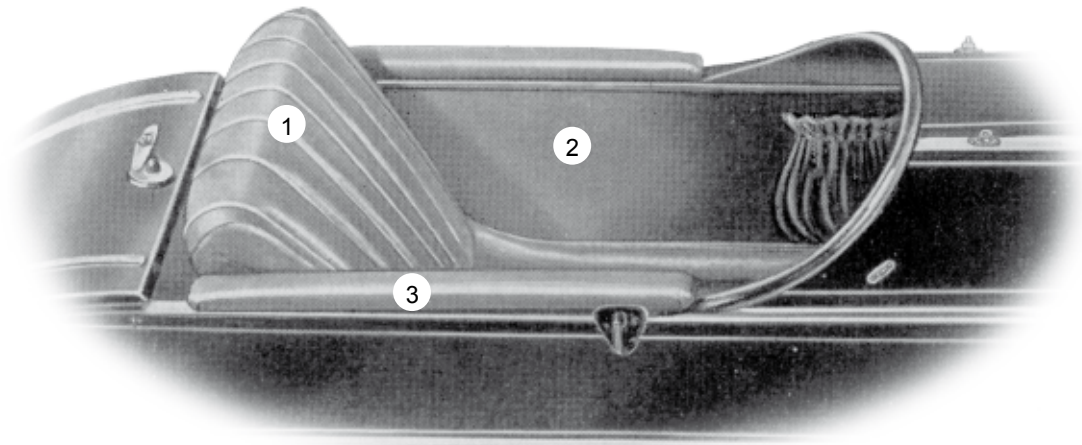

pict.	order-no.	article	price
1	S600z06er/es	seat LS 200 and original S 350: simple , foam rubber, <i>red or black</i>	135,00 €
1	S600z06or/os	original , foam rubber & springs, <i>red or black</i>	185,00 €
1	S600z06sr/ss S200z53b	superior quality , springs, white contour, <i>red or black</i> steel sheet for seatlock LS 200 and original S 350, stainless, mounted at seat	205,00 € 8,00 €
1	S600z08er/es	seat S 500 and S 350: simple , foam rubber, <i>red or black</i>	135,00 €
1	S600z08or/os	original , foam rubber & springs, <i>red or black</i>	185,00 €
1	S600z08sr/ss	superior quality , springs, white contour, <i>red or black</i>	205,00 €
	S600z63or/os	seat TR 500: original , springs, white contour, <i>red or black</i>	249,00 €
	S600z63orR/osR	backpart , single, <i>red or black</i>	125,00 €
	S600z63orS/osS	seatpart , single, <i>red or black</i>	125,00 €
	S600z75.2r/2s	seat MZ , suitable for Stoye TM & Elastik, original, springs, <i>red or black</i>	165,00 €
	S600z71.1r/s/g	seat suitable f. Stoye SM , narrow, original, foam rubber, <i>red or black or grey</i>	139,00 €
2	S123z6Pr/Ps	upholstery pannels, pair with map pocket: LS 200 , <i>red or black</i>	85,00 €
2	S600z18Pr/Ps	S 350 , original, <i>red or black</i>	85,00 €
2	S600z19Pr/Ps	S 500 , <i>red or black</i>	85,00 €
	S123z11Pr/Ps	TR 500 , <i>red or black</i>	85,00 €
3	S400z80r/s	arm rest, pair: LS 200 , <i>red or black</i>	26,00 €
3	S400z81r/s	S 500 , <i>red or black</i>	26,00 €
	S200z104r/s	TR 500 , <i>red or black</i>	26,00 €
	S103z363	floor carpet set for LS 200 , two pieces, for boat & luggage room	39,50 €
	S103z362	floor carpet set for S 350/S 500 , two pieces, for boat & luggage room	39,50 €
	S103z36	floor carpet set for TR 500 , two pieces, for boat & luggage room	42,00 €
	S103z361	floor carpet set for S 250 , two pieces, for boat & luggage room	39,50 €

dust covers – windscreens

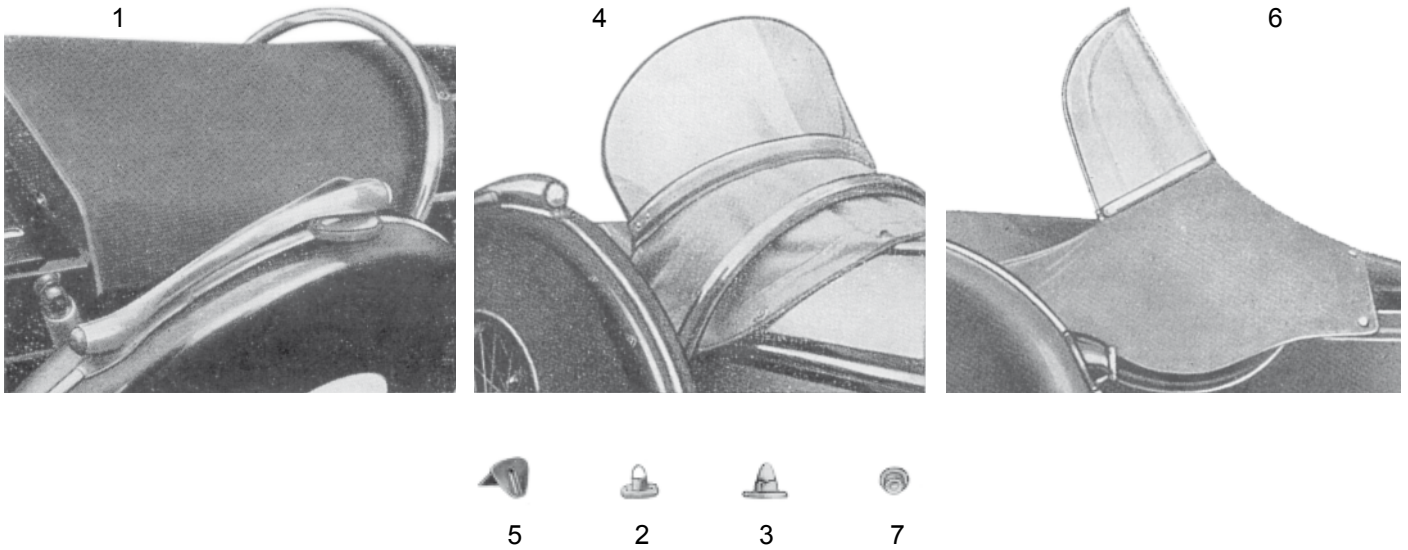

pict.	order-no.	article	price
1	S600z9S	dust cover LS 200 & orig. S 350 , black, red contour, mercedes cloth (fixing parts set S600z16Ö not included)	85,00 €
	S600z16S	dust cover S 350 / S 500 , black, red contour, mercedes cloth (fixing parts set S600z16Ö not included)	85,00 €
	S600z16Sw	dust cover S 350 / S 500 , black, black contour, mercedes cloth (fixing parts set S600z16Ö not included)	85,00 €
	S600z62S	dust cover TR 500 , black, red contour, mercedes cloth (fixing parts set S600z62Ö not included)	95,00 €
	S600z62Sw	dust cover TR 500 , black, black contour, mercedes cloth (fixing parts set S600z62Ö not included)	95,00 €
	S600z161S	dust cover S 250 , black, red contour, mercedes cloth (fixing parts set S600z16Ö not included)	89,00 €
2	S200z16	turnbuckle fastener for dust cover , 8 mm	1,60 €
3	S200z16h	turnbuckle fastener for dust cover <u>and</u> windscreens , 10 mm	1,60 €
	S600z16Ö	fixing parts set for dust cover <u>and</u> windscreens, LS 200 – S 500 , complete	22,95 €
	S600z62Ö	fixing parts set for dust cover <u>and</u> windscreens, TR 500 , complete	22,95 €
4	S600z16WI	windscreen for LS 200 – S 500 , with cover, (requires two holders S200z15Vk)	139,00 €
5	S200z15Vk	windscreen-holders , stainless, polished, for LS 200 – S 500, for mounting under armrests	17,90 €
6	S600z62Wk	windscreen, for TR 500 , complete, with cover, requires bolts (S600z62WB)	239,00 €
7	S600z62WD	button snap fastener , for windscreen	1,00 €
	S600z62WB	bolts for TR 500 windscreen , 4 bolts, stainless, 4 stainless washers,	55,90 €
	S600z08KN	head nail , type stud	4,90 €
	S151z28VA	screw M 4 x 16 , stainless, for LS 200 – S 500	0,30 €
	S151z16VA	screw M 4 x 8 , stainless, for LS 200 – TR 500	0,30 €
	S152z16	ferrule round , for dust cover / windscreens single	1,00 €
	S152z17	ferrule oval , for dust cover / windscreens single	1,00 €

manuals and spare part lists

order-no.	article	price
	STEIB sidecars	
SPN 0012	Nachdruck des Gesamtprospektes 1938 mit den Modellen: Reise-, Touren-, Luxus-, Sport- und Aluminium-Seitenwagen, schwarz/weiß, ca. 4 Seiten 17 x 24 cm	4,00 €
SWK 0504	Hydraulische Seitenwagen-Bremse, Ersatzteilkatalog und Betriebsanleitung, ca. 30 Seiten A5	15,00 €
SWK 0056	Ersatzteilkatalog, Ausgabe 1948/49, LS 200, S 350, S 500, ca. 60 Seiten A 5	20,00 €
SWK 0032	Ersatzteilkatalog, Ausgabe 1955, LS 200, S 350, S 500 L, TR 500, LT 200, RS 1, 120 Seiten A5	29,00 €
SWK 0347	Ersatzteilkatalog, Ausgabe 1952, LS 200, LT 200, S 350, TR 500, S 500	25,00 €
SWK 1725	Prospekt 1955 (Reprint), LS 200, S 250, S 350, S 501, LT 200, TR 500, Roller 1 und 2, 2-Farb-D.	12,00 €
SWP 1632	Poster 1936, 4-Farb-Druck, ca. 50 x 70 cm	9,23 €
SWP 1633	Miniposter STEIB 1936, 4-Farb-Druck, ca. 30 x 40 cm	5,13 €
SWP 0518	Werbeposter (Nachkrieg), 2-Farb-Druck, ca. 50 x 70 cm	9,23 €
SWP 1724	Kollektions-Plakat 1955, mit 9 Modellen im 1-Farb-Druck, ca. 50 x 70 cm	9,23 €
	STOLZ sidecars Berlin	
SPN 0013	Gesamtprospekt, Ausgabe ca. 1954, Modelle: Sport, Super Sport, Safari Rollerseitenwagen, Berlin, Sport Luxus, Spezial Rennseitenwagen, Geländesport, Transport, s/w, 8 Seiten 17 x 24 cm	10,00 €
	STOYE sidecars	
SWK 1649	Ersatzteilkatalog, Stoye TM, Elastik, MZ-Superelastik, 20 Seiten	15,00 €
SWK 2310	Prospekte ab 1936, Zeichnungen und Beschreibungen von über 10 verschiedenen Typen, s/w, 21 S.	15,00 €
	ROYAL sidecars	
SWK 2400	Prospektsammlung, Reprint, s/w, 30 Seiten	20,00 €
	BINDER sidecars	
SPC 0015	Prospekt, Typen BKS und BKLS, 4 Abb., 2-farbig, 4 Seiten DIN A5, Kopie in Originalgröße	10,00 €
	FELBER sidecars	
SVV 1	Prospekt 1951, Lieferbeiwagen, Standard-Sport-offen, Sport-Cabriolet-Standard, Reise-Cabriolet-Luxus, Reise-Limousine, 18 Seiten DIN A5, Reprint mit 4-farbigem Titelblatt	18,00 €
SVV 2	Prospekt, Bogenchassisbeiwagen, Kanu L37 Cabriolet, Reise-Cabriolet 37, Fahrer-Windschutz, Motorrad- und Autoanhänger, 18 Seiten ca. DIN A5, Reprint	18,00 €
SVV 3	Prospekt, Standard- und Luxus-Cabriolet, 14 Seiten DIN A5, Reprint	15,00 €
	BMW	
	Werkstatthandbücher mit ausführlicher Darstellung des Seitenwagenanbaus:	
SWH 25	R 25	29,00 €
SWH 25/2	Nachträge für R 25/2, R 25/3	22,00 €
SWH 26	R 26/27	36,00 €
SWH 51/2	R 51/2	36,00 €
SWH 51/3	R 51/3, R 67, R 67/2	36,00 €
SWH 50	R 50, R 60, R 69 S	36,00 €
X000 0005	T-shirt with Steib-imprint	15,00 €



motorbike parts

BMW R 24 – R 27

we have the full range of spare parts for all single cylinder BMW's models. Parts are available newly produced, used or in exchange. You can purchase tank pads, handlebar equipment, crown ring sets and several other parts from our own production

BMW R 51 / 2 – R 68

a selected range of often needed parts: wiring harness, exhaust pipes and silencers, saddles, tank pads, bearings, handlebar equipment and many others. More are available on request. Ask for it.

BMW R 50 – R 69 S

selected range of often needed parts: wiring harness, exhaust pipes and silencers, saddles, tank pads, bearings, handlebar equipment and many others. More are available on request. Ask for it.

BMW R 2, R4, BMW R 35 / EMW R 35

several new and used parts: exhaust pipes and silencers, wiring harness, speedometer, handlebar equipment, mudguards, engine parts and many others. More are available on request. Ask for it.

Please have a look at our handlebar equipment pages for all prewar and postwar motorcycles.

Ask for parts of NSU, HOREX and many other makes of the 1950's.

Also we have reprints of spare parts lists, operating instructions, workshop manuals and catalogues for most German motorcycles makes of the 1930's to the 1960's. Please have a look at page before.

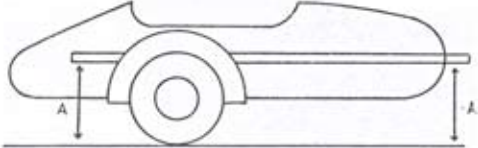
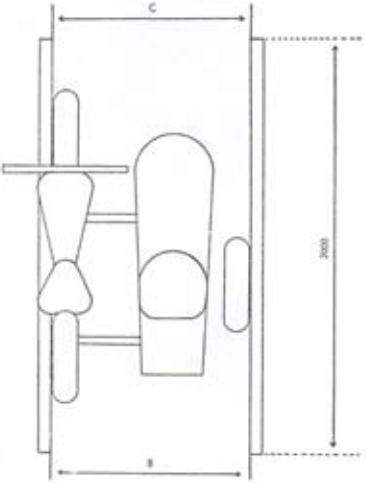
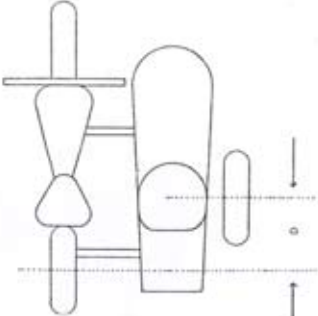
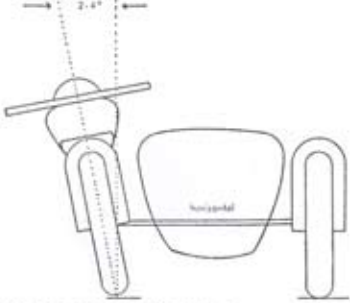
 <p>Spezialfabrik für Seitenwagen Nürnberg</p>	<h3>Montage-Anleitung</h3> <p>zum Anbau eines Seitenwagens</p>	<p>Nr. 500z9</p>
<div data-bbox="215 1108 694 1254"></div> <div data-bbox="215 1276 694 1366"><p>Einstellung des Rahmens: Abstand A des unbelasteten Rahmens vorne und hinten zum Boden möglichst gleich hoch einstellen.</p></div> <div data-bbox="247 1388 614 1870"></div> <div data-bbox="215 1892 694 2027"><p>Einstellung der Vorspur: Die Vorspur wird mit einer am Seitenwagenrad, sowie Vorder- und Hinterrad anliegenden 2 m langen Meßlatte gemessen, wobei C ca. 20-35 mm (größere Werte gelten für größere Maschinen) kleiner als B ist.</p></div> <div data-bbox="957 1108 1276 1422"></div> <div data-bbox="909 1433 1380 1556"><p>Einstellung der Voreilung: Die Achse des Seitenwagenrades muß der Hinterachse des Kraftrades um das Maß D ca. 150 - 250 mm (die größeren Werte gelten für größere Maschinen) voreilen.</p></div> <div data-bbox="933 1568 1284 1870"></div> <div data-bbox="909 1870 1380 2027"><p>Sturz des Kraftrades: Der Sturz des Seitenwagenrades wird nicht mehr eingestellt, sondern nur horizontal zur Fahrzeugebene an das Kraftrad angeschlossen. Der Sturz des Kraftrades soll entsprechend der Schwerpunktlage des Kraftrades, sowie unter Berücksichtigung der Straßenverhältnisse 2-4° betragen.</p></div>		

our sidecars

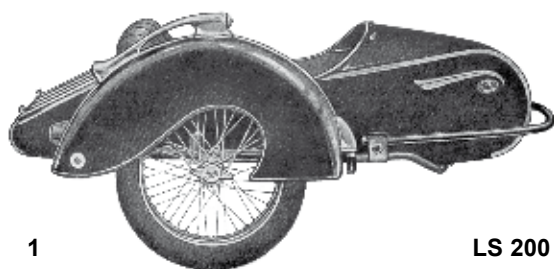

1

LS 200

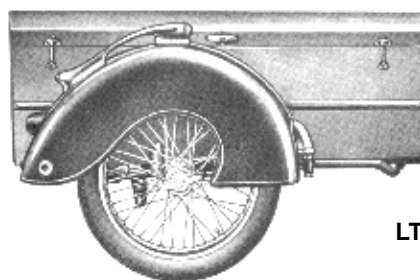

2

LT 200

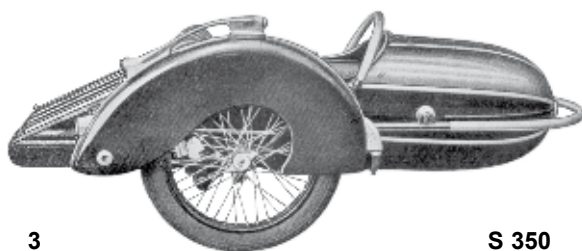

3

S 350

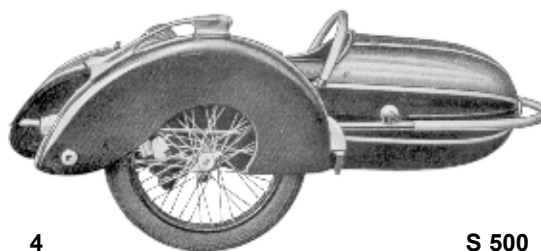

4

S 500

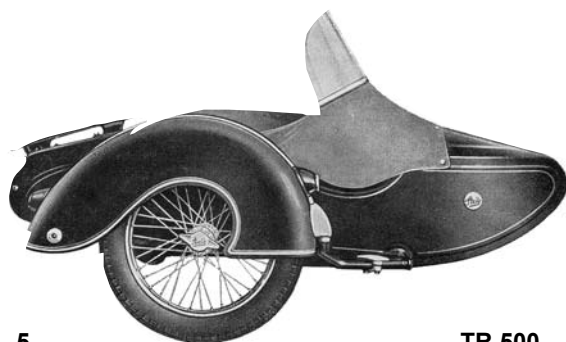

5

TR 500

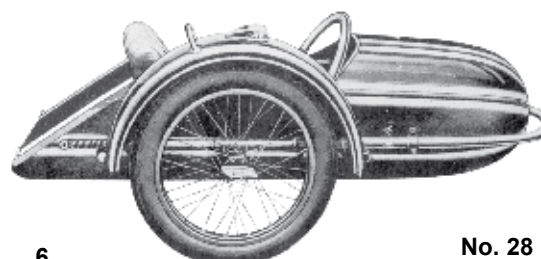

6

No. 28

sidecars equipment

Sidecars come primed with: red interior, carpet set, arm rests, foot rest, foot step, position lamp, ID-plate, luggage bars, lock for luggage door, Cobra lamp & wire, wheel, tire, wing nut, 4 connectors. Not included: dustcover, windscreen, crating. **Sidecar boats come primed with:** alu trim, front badge, footrest, luggage bars. Not included: seat, interior upholstery & suspension, crating. Prices for more or less equipped sidecars & boats on request.

We do paintjob and lining on demand.

All prices with 16% V.A.T. We reserve the rights to price changes. Estimates are subject to change and not binding.

Actual information on our homepage www.ideal-seitenwagen.de!

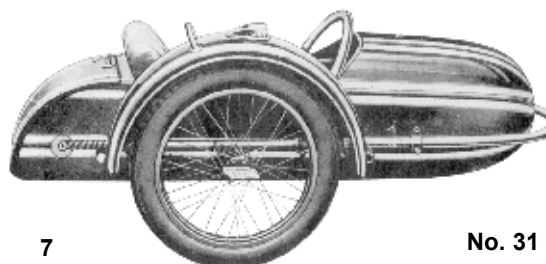

7

No. 31

pict.	order-no.	sidecars – primed	price
1	S701z09	STEIB sidecars of the mid-50's: LS 200 – also for left side mounting!	3.390,00 €
2	S701z10	LT 200 – also for left side mounting!	3.350,00 €
3	S701z11	S 350 – also for left side mounting!	3.690,00 €
4	S701z16	S 500 – also for left side mounting!	3.990,00 €
5	S701z61G	TR 500 rubber suspension	4.290,00 €
	S701z61F	TR 500 leaf spring suspension	4.490,00 €
6	S701z12	STEIB sidecars of the mid-30's: No. 28 – the sportly!	3.690,00 €
7	S701z13	No. 31 – the traveller!	3.895,00 €
	0000001010	paintjob of a sidecar	990,00 €
	0000001009	extra charge for left hand side connection	310,00 €